





## Freestanding UV Glass Dryers

-  stencil processing
-  screen printing
-  air force
-  ultra violet
-  infra red



Natgraph manufacture a range of Freestanding Ultra Violet (UV) Glass Dryers developed from years of experience gained in the production of over 500 conveyorised UV Dryers that are in world-wide daily use. Natgraph UV Dryers are widely acknowledged as the coolest and most efficient available.

These dryers have been designed for curing UV surface coatings applied to glass, in the

automotive and gaming machine industries. Whatever the requirement for curing a UV ink onto glass, Natgraph have a solution.

With 8 standard belt widths, 2 transport systems, Touch Screen PLC Control Systems, 4 layouts, optional pre IR, Ozone Filters and Intelligent UV Control Systems, this range of dryers is extremely adaptable, versatile and efficient.

### Freestanding UV Glass Dryers



# Freestanding UV Glass Dryers

## Freestanding UV Glass Dryers

### Features

- Touch Screen PLC Control System
- High efficiency fully focused reflectors
- Curing from above and below the glass
- Inter-lamp cooling zone
- After cure cooling zone
- Castors and jacking feet



3 lamp UV Glass Dryer with driven peek wheels

The Natgraph range of Freestanding UV Glass Dryers are designed to meet the requirements of flat glass printing operations and are built to the same modular design as Natgraph's Air Force Dryers. Available in 8 standard curing widths from 90cm through to 260cm, all standard glass formats can be processed.

High efficiency lamphouses are positioned above and below the transport system to ensure full cure of the dense black UV inks used for automotive glass. 2 lamps above and 1 below are vital to ensure curing of large areas of ink, particularly when screen printed onto dark 'sun screen' glass.

Natgraph's UV technology is acknowledged as the coolest running and most efficient available. This has been achieved with extensive knowledge of discharge lamp requirements for optimum performance and the use of Natgraph's in-house manufactured transformer systems.

The standard inlet section is 1m with control box attached, however the length of the inlet section can be increased by the addition of extra modules for large format printing as well as operation with more than one printing machine. The standard belt is of an open mesh P.T.F.E. coated fibre glass construction, with reinforced edges and protective flap below the joint. The lamp located below the belt shines through the belt itself.

The alternative transport system is a set of driven rollers fitted with peek wheels, this material is not affected by the high UV intensity or temperature within the dryer. This system gives an unobstructed light path from the lamp below and is ideal for glass over 300mm in size.

Operation of the dryer is via a Natgraph Touch Screen PLC Control System. This includes belt speed (3 – 50m/minute, 0.1m resolution, via a feedback loop), as well as independent control of each UV lamp, including lamp power level, lamp hour meters (re-settable), total hour meters (non re-settable) and lamp current monitoring with virtual ammeters. A dryer fault diagnostic system is included with on-screen

indication of fault conditions (logged by date/time). A comprehensive safety system is installed in all Natgraph UV dryers, this includes lamp current monitoring, positive disconnect safety switches, air pressure switches, earth leakage sensor, thermal switches within the transformers and a minimum speed cut-out device for the belt. These are all linked to a warning siren to alert the operator in the unlikely event of any technical problems. A service due indicator is also included and a large hinged access door allows easy access to the lamphouses for quick lamp change.

3 high-powered UV lamps are installed in the 2m module, which has internal gas filled lifting arms to raise the hood for maintenance etc. The all aluminium lamphouses have high efficiency, fully focused anodised aluminium reflectors fitted and all ozone produced by the lamps is extracted.

The medium pressure, mercury vapour lamps are run at 120 watts/cm (300 watts/inch) on high power and 80 watts/cm (250 watts/inch) on low power. The lamphouses are separated by a short cooling section and followed by a 1m wide ambient cooling zone, fitted with galvanised jet plates. This air system is designed to ensure a balanced airflow to take the minimum amount of air from the print room. Natgraph design and in-house manufacture their own unique transformer system to guarantee the most efficient operation and the highest possible quality of their range of UV dryers.

The 0.5m exit section, which can be extended, contains the belt drive motor, drive linkage tensioning device and drive rollers.

Purpose built versions of the dryer using doped lamps with different spectral wavelengths, as well as higher power outputs for specialised inks are available. Special height legs are also available as well as pneumatically operated drop down inlets to ensure the dryers are fully compatible with all printing machines.

These dryers require a three phase power supply.



In-house manufactured transformers



2 UV lamps above and 1 below peek wheels



EQUIPMENT SOLUTIONS





# Freestanding UV Glass Dryers

## Ozone Filters



Ozone Filter

Natgraph have designed Ozone Filter units to operate with their range of UV Dryers. Ozone gases are produced by UV lamps and must be extracted from the dryer efficiently. The ozone is normally extracted from the dryer through ducting to the outside of the building. All of Natgraph's UV Dryers have an efficient and fully sealed extraction system to ensure that all the ozone produced is removed.

If there is no easy route to the outside of the factory, or there are environmental reasons that gases or noise should not be emitted from the

factory, then the ozone must be removed by a filter system. Natgraph's Ozone Filter does this and also allows the heat generated by the UV dryer to be re-used within the factory, thus saving on heating costs.

There is a replaceable pre-filter that removes any airborne particles within the unit. If this filter is regularly replaced, then the charcoal filters within the unit will never need to be changed. These units are designed to function without reducing the efficiency of the UV dryer.



Easy access raising hood



3 Lamp Freestanding UV Glass Dryer



# Specifications

## Freestanding UV Glass Dryers

The following details are common to all Freestanding UV Dryers.

1m entry, 2m UV/Cooler, 0.5m exit. (1m exit on model 260)

**Belt Height** 79 – 90cm (31" – 37") Adjustable by the module's feet. (Higher options available)

**Belt Speed** 2 – 20m per minute (6 – 60') Other speeds are available to order.

**Height** 114 – 129cm (45" – 51") Adjustable by the modules feet.

**Length** All standard models are 3.5m (138") long, except model 260 which is 4m (156") long.

**Voltage** Three Phase 400 Volts 50/60Hz. AC

These figures apply to individual model sizes.

Model No.	90	110	130	155	170	185	215	260
<b>Belt/Curing Width</b>	90cm (36")	110cm (43")	130cm (51")	155cm (61")	170cm (67")	185cm (73")	215cm (84")	260 (102")
<b>Width</b>	158cm (62")	178cm (70")	198cm (78")	223cm (88")	238cm (94")	253cm (100")	283cm (112")	370 cm (145")
<b>Weight</b>	910kgs. (2006lbs.)	1130kgs. (2486lbs.)	1320kgs. (2910lbs.)	1510kgs. (3322lbs.)	1700kgs. (3740lbs.)	1870kgs. (4114lbs.)	2010kgs. (4422lbs.)	3000kgs (6600lbs)

The following power figures are for 3 lamps at full power, 120 watts/cm (300 watts/inch).

<b>Power</b>	38kW	48kW	56kW	66kW	72kW	80kW	93kW	115kW
<b>Current</b>	55	67	80	95	105	119	136	115

The following air volumes are in 1,000m<sup>3</sup>/hour

<b>Air Intake</b>	2.8	3.2	3.8	4	4.3	4.8	5.6	6
<b>Extracted</b>	2.9	3.4	4	4.2	4.6	5	5.8	6

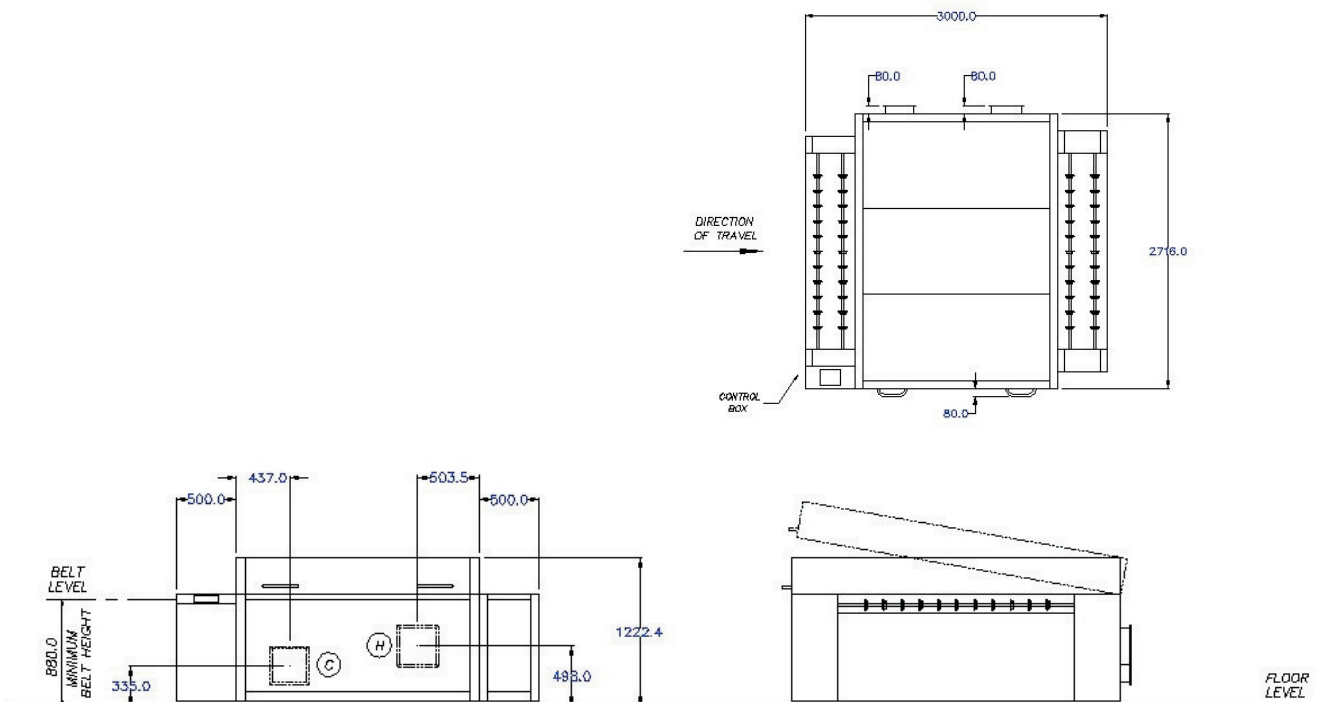

Distributed by:

**Natgraph**

Download our brochures at [www.natgraph.co.uk](http://www.natgraph.co.uk)